

ANTARES 20 / 30



BESCHREIBUNG | DESCRIPTION

hochwertige Scheibenleuchte im schlanken Design für alle gängigen Lichtbandsysteme, erhältlich in verschiedenen Erkennungsweiten

high quality edge luminaire in slimline design for marketable lighting strip system, available in different viewing distances

Erkennungsweite
viewing distance

20 m / 30 m

Schutzart
protection degree

IP40

Schutzklasse
protection class

I

Gehäuse
housing

Stahlblech, weiß RAL 9016

Scheibe Acrylglas

steel sheet, white RAL 9016

acrylic glass glass pane

Serie S

Serie P

SC

Zentralbatterie | central battery

Einzelbatterie | single battery

TECHNISCHE DATEN | SPECIFICATIONS

	Anschlussspannung supply voltage (AC/DC)	Anschlussleistung power rating (AC/DC)	Umgebungstemperatur ambient temperature	Gewicht weight	LiFePo4-Akku LiFePo4 accu
Zentralbatterie central battery	230 V / 216 V	8,5 VA / 4,5 W	-10° C <> +40° C	0,8 kg	-
Einzelbatterie single battery	230 V / -	7,0 VA / -	-5° C <> +35° C	1,0 kg	3 h / 8 h

MABE | DIMENSION (mm)

ANTARES 20

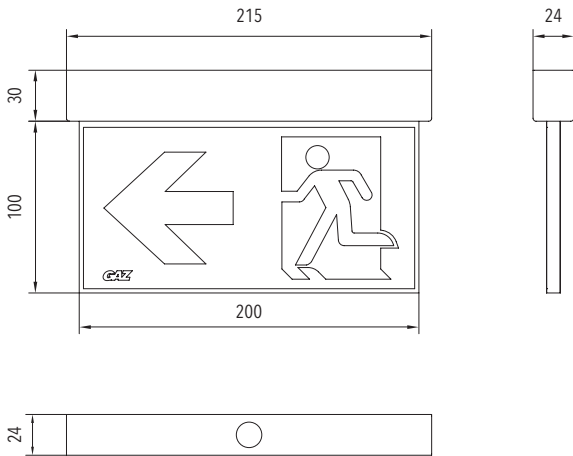

ANTARES 30

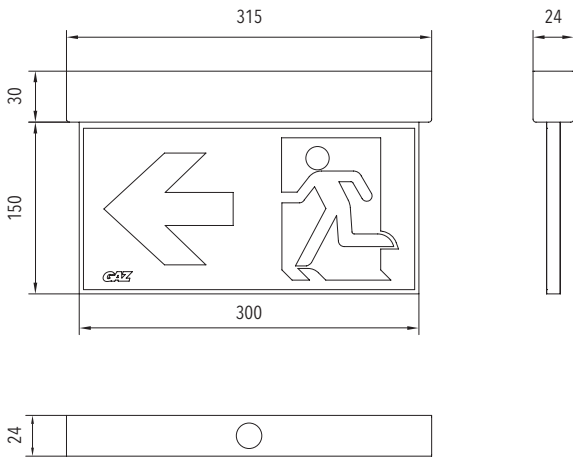

erforderliche Maße des Lichtbandsystems
required dimensions of lighting strip system

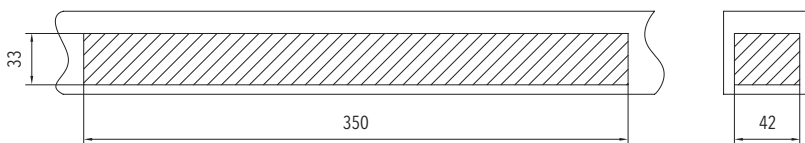

ZUBEHÖR | ACCESSORIES

Bezeichnung | designation

Sonderpiktogramme
special pictograms



G-CONTROL Gerätetechnik

Die GAZ bietet die passende Gerätetechnik (Serie S und P) und Zubehör
GAZ offers equipment technology (serie S and P) and accessories



www.gaz.de