

G-LUX PLUS



BESCHREIBUNG | DESCRIPTION

kleiner robuster Handscheinwerfer mit schwenkbarem Lampenkopf

small robust portable spotlight with swiveling lamp head

Schutzart <i>protection degree</i>	IP44
Schutzklasse <i>protection class</i>	III
Gehäuse <i>housing</i>	Kunststoff, schlagfest <i>plastic, impact resistant</i>
Einstellungen <i>settings</i>	3 Helligkeitsstufen 5.300 K (tageslichtweiß) <i>3 brightness levels</i> 5.300 K (daylight white)

TECHNISCHE DATEN | SPECIFICATIONS

Versorgung <i>supply</i>	Anschlussspannung <i>supply voltage</i> (AC/DC)	Anschlussleistung <i>power rating</i> (AC/DC)	Umgebungs- temperatur <i>ambient temperature</i>	Leuchtmittel <i>illuminant</i>	Akku <i>accu</i>
Einzelbatterie <i>single battery</i>	230 V / -	12 VA / -	-10° C <> +50° C	3 W / 300 lm	bis zu 30 h <i>up to 30 hours</i>

MABE | DIMENSION (mm)

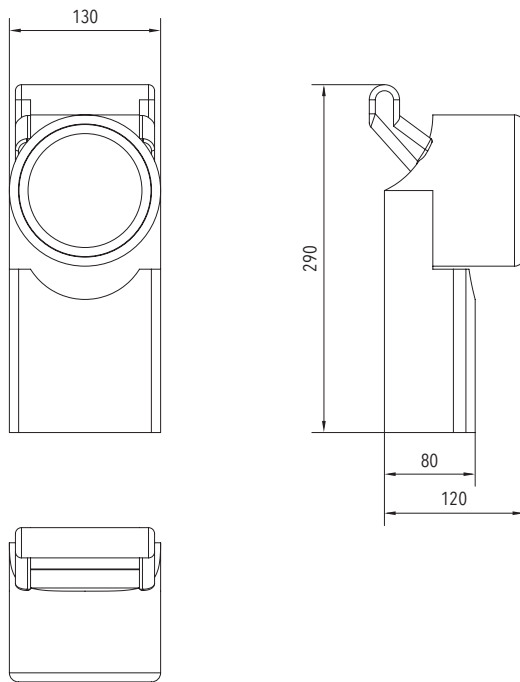

BESTELLANGABEN | ORDER INFORMATION

Bezeichnung designation	Art.-Nr. item no
Handscheinwerfer G-LUX PLUS	1211800055

INKL. ZUBEHÖR | INCL. ACCESSORIES

Wandhalter für Wandmontage
wall bracket for wall mounting

230 V Netzteil
230 V power supply

12 V KFZ-Ladekabel
12 V car charging cable

Streuscheibe orange
diffusing panel orange

