

# SIGMA M



## BESCHREIBUNG | DESCRIPTION

kompakter Notlichtstrahler mit separat schwenkbaren Scheinwerfern

*compact emergency lighting fixtures with individual swivelling headlights*

Schutzart <i>protection degree</i>	IP54
Schutzklasse <i>protection class</i>	I
Gehäuse <i>housing</i>	Stahlblech lichtgrau RAL 7035 <i>steel sheet light grey RAL 7035</i>

SC

Einzelbatterie | *single battery*

## TECHNISCHE DATEN | SPECIFICATIONS

	Anschlussspannung <i>supply voltage (AC/DC)</i>	Anschlussleistung <i>power rating (AC/DC)</i>	Umgebungstemperatur <i>ambient temperature</i>	Gewicht <i>weight</i>	Lichtstrom <i>luminous flux</i>	Pb-Akku <i>Pb accu</i>
Einzelbatterie <i>single battery</i>	230 V / -	2 x 22,0 W	-5° C <> +35° C	14,0 kg	2 x 1500 lm	3 h

## MABE | DIMENSION (mm)

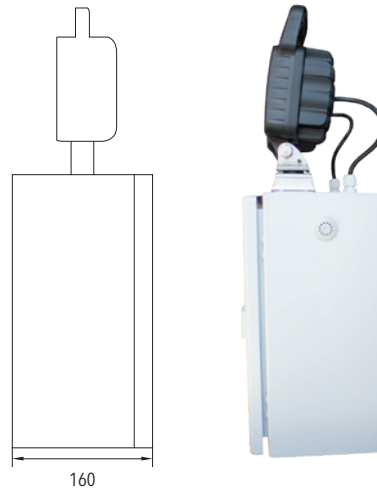
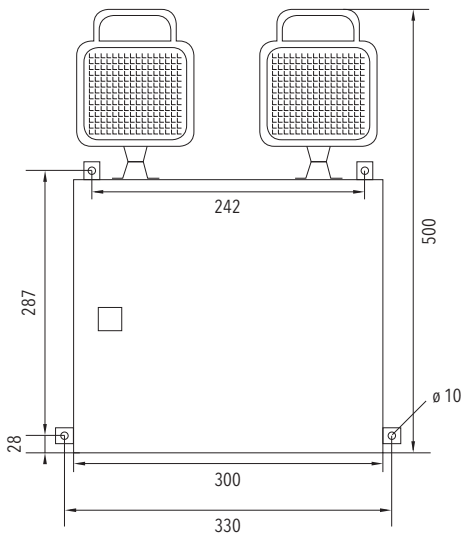

### LED-Zustandsanzeige LED status integrator

- grün  
green      kein Fehler, Netzbetrieb  
no fault, mains operation
- grün blinkend  
flashing green      Prüfzyklus  
test cycle
- rot  
red      Notbetrieb  
emergency operation
- rot blinkend 1 x  
flashing red 1 x      Batteriespannungsfehler  
battery voltage error
- rot blinkend 2 x  
flashing red 2 x      Batterieladefehler  
failure in battery charging
- rot blinkend 3 x  
flashing red 3 x      Temperaturfehler >80 °C  
temperature error >80 °C
- rot blinkend 4 x  
flashing red 4 x      Leuchtmittelfehler  
failure in illuminant

## BESTELLANGABEN | ORDER INFORMATION

Bezeichnung   designation	Art.-Nr.   item no
SIGMA M	1490022000

**SIGMA M mieten · Tel. 0375 77066-0**  
rent SIGMA M · phone +49 375 77066-0

Durch SIGMA M ist das sichere Verlassen des Veranstaltungsortes im Gefahrenfall gewährleistet.  
The SIGMA M guarantees a safe evacuation from the venue in case of danger.

