

G-LIGHT TWIN



BESCHREIBUNG | DESCRIPTION

kompakter Notlichtstrahler mit separat schwenkbaren Scheinwerfern

compact emergency lighting fixtures with individual swivelling headlights

Schutzart IP54
protection degree

Schutzklasse I
protection class

Gehäuse Stahlblech, RAL 7035
housing steel sheet, RAL 7035

SC

TECHNISCHE DATEN | SPECIFICATIONS

Versorgung <i>supply</i>	Anschlussspannung <i>supply voltage</i> (AC/DC)	Umgebungs- temperatur <i>ambient temperature</i>	Leuchtmittel <i>illuminant</i>	Pb-Akku <i>Pb accu</i>
Einzelbatterie <i>single battery</i> SC	230 V / -	-5° C <> +35° C	2 x 22 W / 2 x 1500 lm	3 h

MABE | DIMENSION (mm)

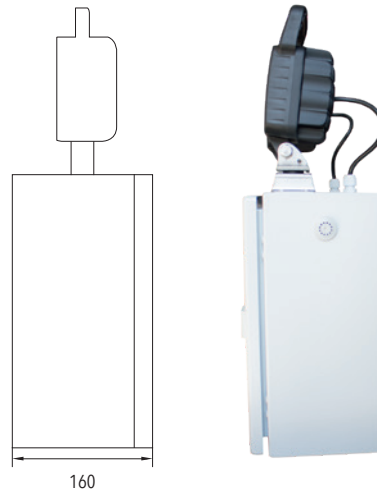
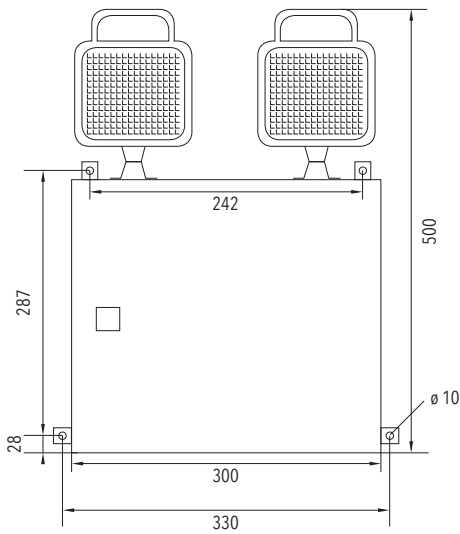

LED-Zustandsanzeige LED status integrator

- grün
green kein Fehler, Netzbetrieb
no fault, mains operation
- grün blinkend
flashing green Prüfzyklus
test cycle
- rot
red Notbetrieb
emergency operation
- rot blinkend 1 x
flashing red 1 x Batteriespannungsfehler
battery voltage error
- rot blinkend 2 x
flashing red 2 x Batterie ladefehler
failure in battery charging
- rot blinkend 3 x
flashing red 3 x Temperaturfehler >80 °C
temperature error >80 °C
- rot blinkend 4 x
flashing red 4 x Leuchtmittelfehler
failure in illuminant

BESTELLANGABEN | ORDER INFORMATION

Bezeichnung designation	Art.-Nr. item no
G-LIGHT Twin	1490022000

G-LIGHT TWIN mieten · Tel. 0375 77066-0
rent G-LIGHT TWIN · phone +49 375 77066-0

Durch die G-LIGHT TWIN ist das sichere Verlassen des Veranstaltungsortes im Gefahrenfall gewährleistet.
The G-LIGHT TWIN guarantees a safe evacuation from the venue in case of danger.

